

space

GN 2/1 REFRIGERATED UPRIGHT CABINETS



Essentiality and reliability are the key words that come to mind in describing the refrigerated cabinets in the "SPACE" range. The one-piece structure features stainless steel on the inside and outside with 60 mm thick insulating core made by injecting HCFCfree high-density polyurethane resins.

The cabinet interior is rounded at the bottom for easy cleaning, the feet and rack support structure are made in stainless steel, while the door is fitted with an easily replaceable slot-in magnetic seal.

The space inside the cabinet can be fully exploited thanks to the one-piece construction and the tropicalized refrigeration system featuring a powerful low-noise compressor.

Refrigeration is fan-assisted and controlled by back panel control board with an electric auto-defrost feature as well as automatic evaporation of condensation.



Back panel control board



Moulded bottom



Tropicalized system



60 mm thick insulation

TECHNICAL DATA:



		EFN/02	EFNV/02	EFB/02
External dimensions (WxDxH)	cm	144x79x202	144x79x202	144x79x202
Capacity	lt	1400	1400	1400
Equipment (Shelves)	nr	6 GN 2/1	6 GN 2/1	6 GN 2/1
Max absorbed power *	W	500	500	1170
Refrigerated power **	W	718*	718*	935
Defrosting heating element	W	300	300	530
Temperature	°C	-2/+8	+2/+10	-18/-21
Gas		R452A	R452A	R452A
Input voltage		1x230V – 60Hz	1x230V – 60Hz	1x230V – 60Hz
Climatic class		5	4	5

*Evap. -10°C cond. +45°C / **ASHRAE (Evap. -23,3°C cond. +54,4°C)

INSTALLATION DIAGRAM:

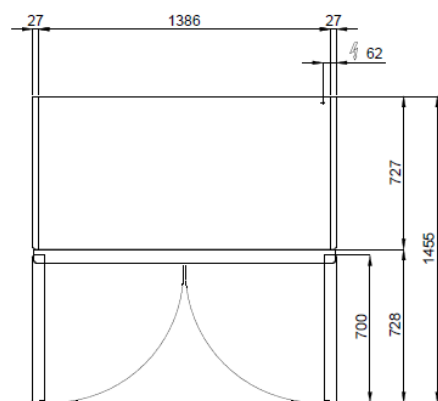
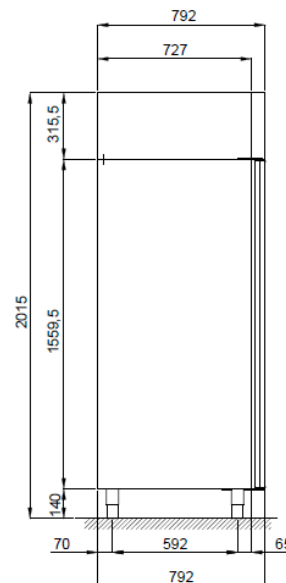
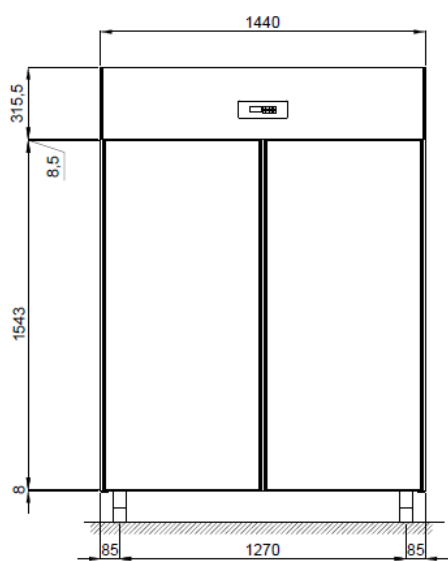

(R) INPUT VOLTAGE: 230V ~ 1-60Hz 1,5mt
CABLE WITH SHUKO

ACCESSORIES AND OVERPRICES ON REQUEST:

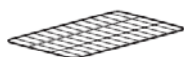

45000500 GN 2/1 shelf



45001550 Pair of runners for GN 2/1 shelf

45000530 Door pedal

45000535 LED light each door

45000537 Door lock with key

45000540 Set of Ø 100 castors

45000543 Pastry structure for 19 60x40cm trays (65 mm pitch) each door (overprice)



45000564 Wi-Fi supervising system



Refrigeration system with R290 gas for normal temp. cabinet (overprice)

Refrigeration system with R290 gas for freezer temp. cabinet (overprice)



Prearranged version with valve system for normal temperature cabinet (deduction)

Prearranged version with valve system for low temperature cabinet (deduction)